



PRODUCTS N°11

Filter Tank

Purpose:

It is applicable to medicine, food, fruit juice beverage, dairy products, wine brewing, bioengineering, daily chemicals, fine chemicals, electronics and other fields.

Structural features:

1. Hygiene level stainless steel is adopted as the material, and 304 (S30408), 304L (S30403), 316 (S31608),

316L (S31603) can be selected according to media or customer's requirement.

2. It conforms to GMP requirement; the internal wall of barrel has circular arc transition with end enclosure and connecting pipe, ensuring hygiene and no dead angle.

3 The built-in filter screen tank adopts sintering process, which is beautiful and solid.

4 The barrel cover adopts quick open structure, which is convenient for cleaning. 5

The surface roughness of product is usually at Ra 0.8~0.2 μ m.

Tank configuration:

1 Adjustable leg

2 Air release valve (optional)

Technical data sheet for filter tank

Effective volume (L)	Tank length (mm)	Internal diameter of tank(mm)	Total height of equipment (mm)	Diameter of material feeding and discharging port (mm)	Quantity of filter screen tank equipped (No.)
20	425	298	750	50	40、80、100、200

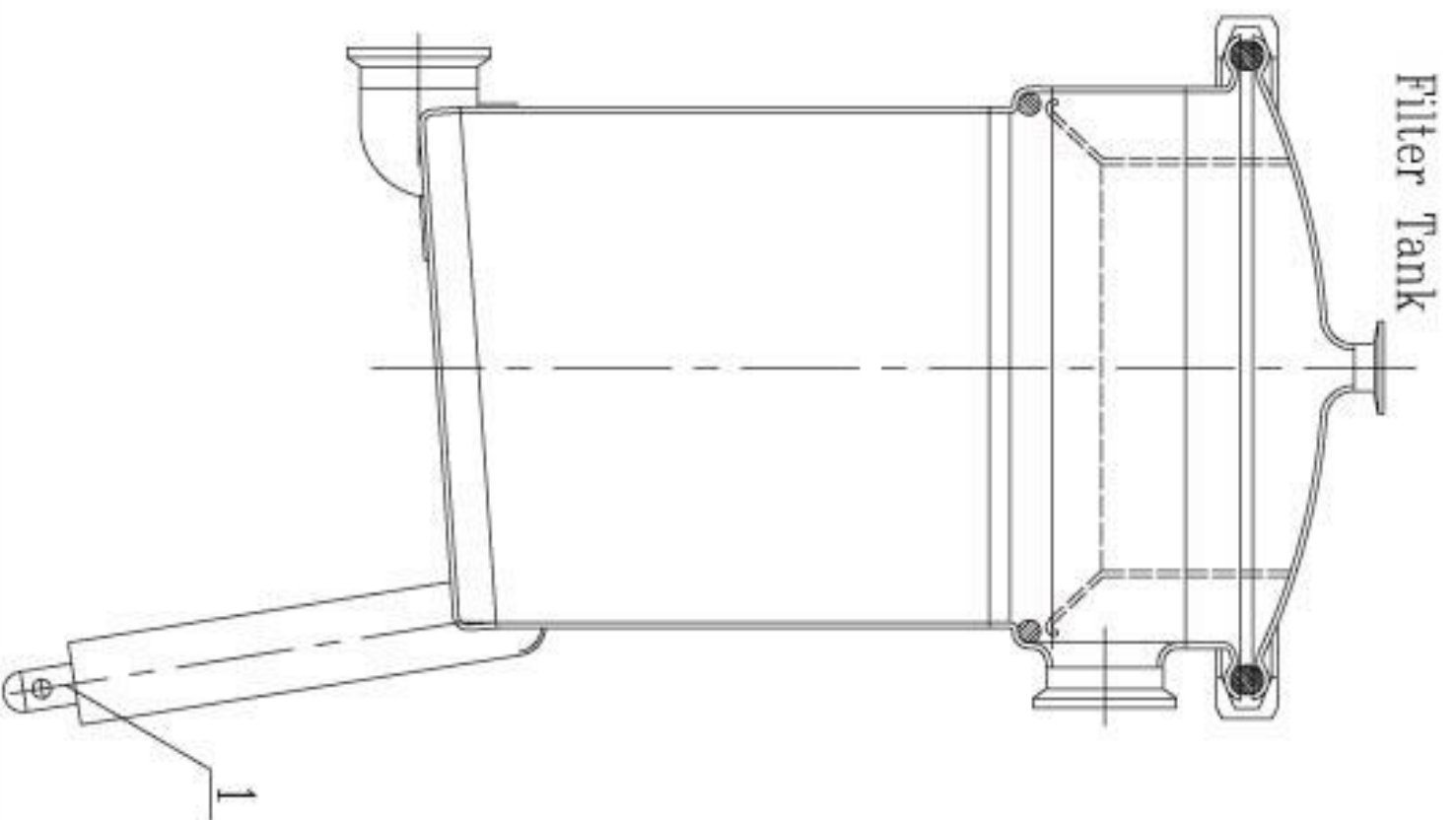

Tank Configuration:

1. Adjustable leg
2. Air release valve(optional)